

# GUIDELINE ON Proper Construction Practices for Non - Engineered Buildings (Stone Masonry)

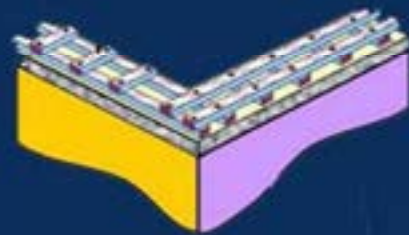
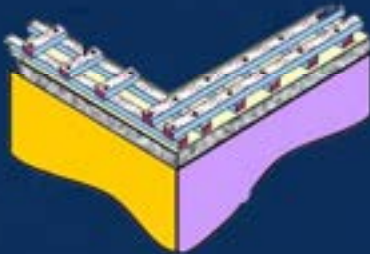

Standards & Quality Control Authority  
Ministry of Works & Human Settlement

## PREFACE

The Earthquake of Magnitude 6.1 on September 21, 2009 that caused severe damages to lives and properties in Eastern Bhutan has re-confirmed the level of seismic activity taking place in our country. The severity of the earthquake and the repeated recurrence of aftershocks reminded us all on the existence of geologically active strata upon which our country lies. The event and its ensuing aftermath have quelled any skepticism on the seismicity of our country and have exposed the vulnerability inherent in our infrastructures, particularly the houses in rural area and buildings in urban areas.

While earthquakes cannot be predicted and prevented, our homes could be made stronger, resilient to shocks and vibrations and therefore safer.

This “Guideline on Proper Construction Practices for Non – Engineered Building –(Stone Masonry)” prepared by the Standards and Quality Control Authority with the financial assistance from UNDP – Bhutan and support from the Department of Disaster Management, MoHCA, provides simple yet effective “planning and construction techniques” to *improve and enhance* the resilience to earthquake events of stone masonry houses.

While the measures recommended in the guideline are made with particular focus on stone masonry construction practices mostly prevalent in our eastern region, the measures could very well be applied to similar building systems elsewhere.

The Ministry of Works and Human Settlements is pleased to bring out this “Guideline on Proper Construction Practice for Stone Masonry Building – 2010”. We hope that the users and home owners find the guideline useful.

The guideline will be periodically reviewed and updated. We welcome any comments and feedback.

**Director – SQCA  
MoWHS**

**Hon’ble Zhabtog Lyonpo  
Ministry of Works and Human Settlement**

**Acknowledgement:**

This document is prepared with the financial assistance from the UNDP – Bhutan Office and coordination support from the Department of Disaster Management, Ministry of Home and Cultural Affairs. Standards and Quality Control Authority would like to thank the two organizations for their support.

The Standards and Quality Control Authority would also like to acknowledge the following individuals for their valuable inputs in developing this document. Without the support of these members, this guide would not have been possible.

1. Karma Jamtsho, Department of Urban Development and Engineering Services, MoWHS;
2. Tshering Dorji, Department of Urban Development and Engineering Services, MoWHS;
3. Karchung, National Housing Development Corporation;
4. Jigme Dorji, City Corporation, Thimphu;
5. Karma Sonam, School Planning and Building Division;
6. Nagtsho Dorji, DCHS, Department of Culture, MoHCA;
7. Dechen Tshering, DCHS, Department of Culture, MoHCA;
8. Junko Mukai, DCHS, Department of Culture, MoHCA;
9. Sonam Tashi, DCHS, Department of Culture, MoHCA;

## Table of Content

<b>1. Purpose and Scope</b> .....	<b>5</b>
1.1 Purpose of the Guideline.....	5
1.2 Scope of the guideline.....	5
<b>2. GENERAL</b> .....	<b>6</b>
2.1 Layout of the Building.....	6
2.2 Site Selection and Foundation.....	7
2.3 Materials.....	8
2.3.1 Soil Field Test:.....	9
<b>3. STONE MASONRY WALLS IN MUD MORTAR</b> .....	<b>10</b>
3.1 Foundation:.....	10
3.2 Course work.....	10
3.3 Through Stones Details.....	11
3.4 Opening in Walls.....	12
3.5 Control on Wall length and Building Height.....	13
3.6 Arrangement of Earthquake resistant elements in single Storey house.....	14
3.6.1 Horizontal Bands in walls.....	14
3.6.2 Horizontal Band at Roof.....	16
3.7 Vertical Reinforcement in walls.....	17
<b>4. STONE MASONRY WALLS USING CEMENT MORTAR</b> .....	<b>20</b>
4.1 Foundation:.....	20
4.2 Course work.....	20
4.3 Through stones.....	21
4.4 Control on Wall Length and Building Height.....	22
4.5 Horizontal Bands in walls with recommended layout of the building.....	23
4.6 Truss to Band connection.....	31
4.6.1 Alternative 1.....	31
4.6.2 Alternative 2.....	31
4.7 Vertical reinforcing rods in walls.....	32
4.7.1 Installation of Vertical Bars:.....	32
<b>5. EARTHQUAKE SAFETY TIPS</b> .....	<b>33</b>
5.1 Before an Earthquake.....	33
5.2 During an Earthquake.....	34
5.3 After an Earthquake.....	35
<b>6. Do's and Don'ts</b> .....	<b>35</b>
6.1 DO's.....	35
6.2 DON'Ts.....	35
<b>7. References:</b> .....	<b>36</b>

## **1. PURPOSE AND SCOPE**

### **1.1 Purpose of the Guideline**

This guideline aims to provide simple techniques and well established construction practices to improve the earthquake resisting capacity of non engineered stone masonry buildings.

### **1.2 Scope of the guideline**

The guideline is prepared with particular focus on houses build with stone masonry. It deals with techniques and good construction practices for stone masonry houses in mud mortar and cement mortar. The guideline covers those houses which are situated in the earthquake prone zones and whose bearing walls are built using coursed stone masonry and the number of storey's are not more than two.

While significant references have been drawn from the existing appropriate internationally accepted codes and guidelines, experiences gained from the observation of the failure and damage pattern of buildings during the 21<sup>st</sup> September 2009 earthquake that hit the eastern parts of Bhutan and from our organizations own engagement in building safety activities has proved very useful in the preparation of the guideline.

The measures proposed are internationally accepted techniques to ***improve/enhance*** the performance of the buildings during earthquakes. It has to be, however, noted that the measures presented in the guideline are to be observed as only good construction practices. Expertise of and consultation with professionals is highly encouraged.

## 2. GENERAL

### 2.1 Layout of the Building

The building should have simple regular and rectangular shape and be symmetrical in both elevation and plan. The walls and openings should be uniformly distributed in both the directions as far as possible.

The Length to width ratio should not exceed 3.

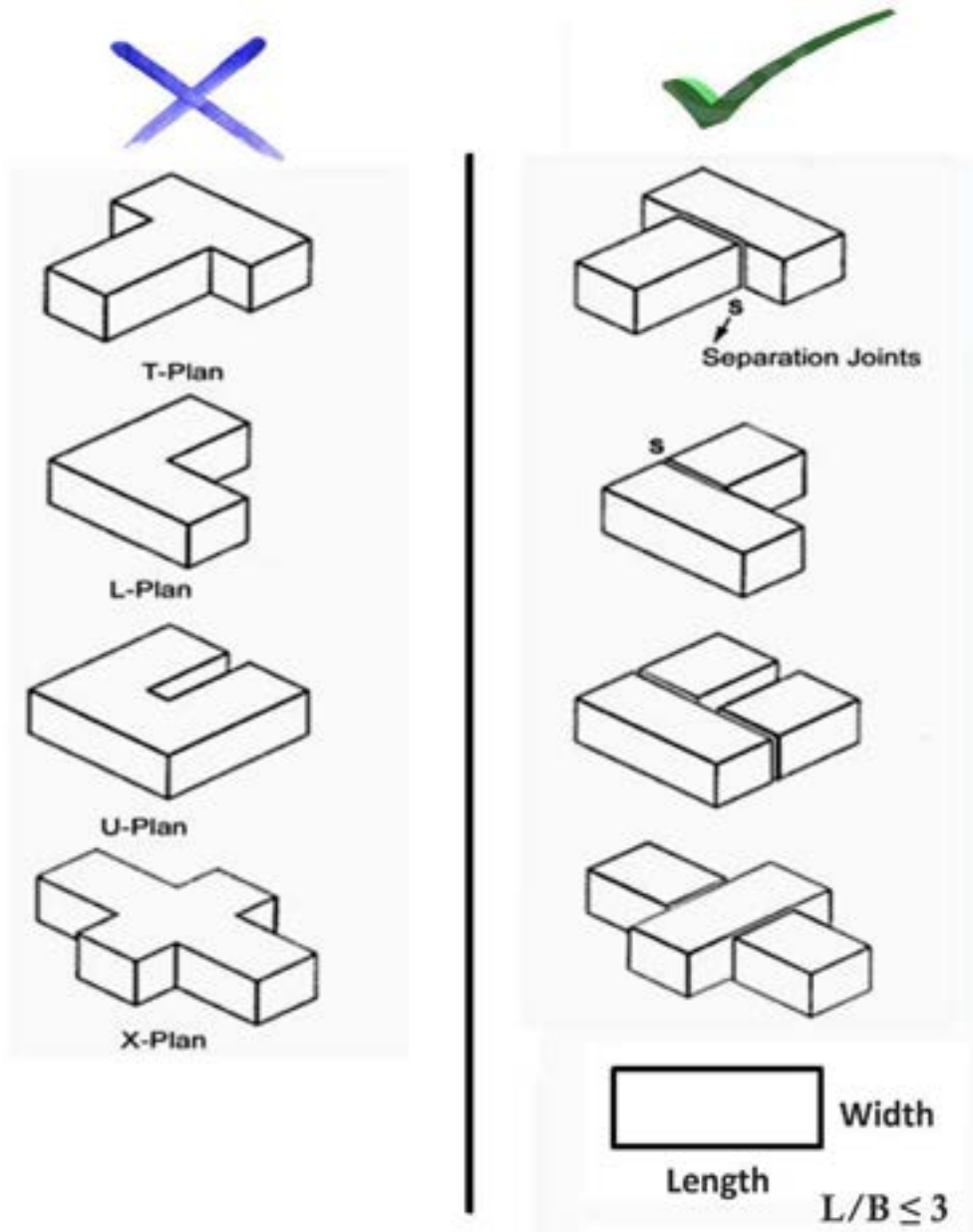

Fig. 1: Layout of the Building

## 2.2 Site Selection and Foundation

The ground under the building has to bear the weight of the house; hence the foundation must be built in a strong soil. Building should not be located too close to steep slope and should not be built on filled up soil.

Avoid water logged soil for foundation as the soil can become liquefied (soil turned into semi-liquid) in an earthquake.



Fig. 2: Example of Bad foundation

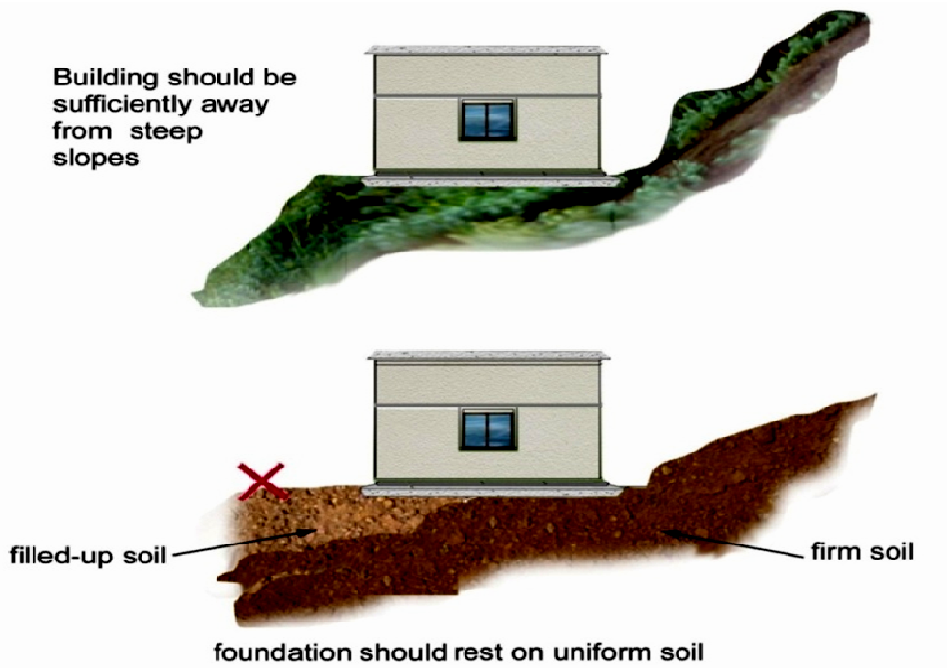

Fig. 3: Site selection

## 2.3 Materials

i. Types of stone:

The common types of stones generally used are natural building stones such as granite and other igneous rocks, lime stones, sandstones, marble, etc.

ii. Durability:

All stones shall be free from defects such as cavities, cracks, flaws, patches of soft or loose materials, etc.

iii. Sizes of stones:

All stones should be small enough to be lifted and placed by hand. The length of the stone shall not exceed 3 times the height and be not less than 200mm. The breadth on base shall not be greater than  $\frac{3}{4}$  of the thickness of wall nor less than 150mm. The height of the stone may be up to 300mm and not less than 100mm.

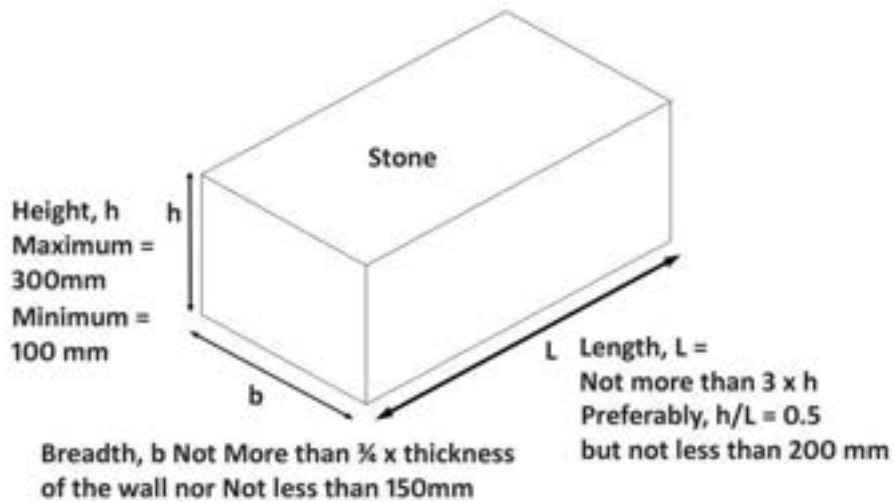

**Fig. 4: Dimension of Stone**

iv. Laying of Stones (coursework):

The courses of the stones shall be laid alternately to break the vertical joints and the stones shall be laid along the grain.



**Fig. 5: Stone Coursework**



v. Mortar:  
The mortar should be cement-sand (1:4), Lime-Sand (1:3) or clay mud of good quality.  
The thickness of mud mortar shall not be more than 30mm and shall be as less as possible.

vi. Soil Selection tips for Mud Mortar:

The clay or mixture of clays should preferably conform to the following mechanical composition.

Clay: 18 – 22% by weight

Silt: 40 – 45 % by weight

Sand: 30 – 40% by weight

The total content of clay and silt be preferably **not less** than 60% by weight.



### 2.3.1 Soil Field Test:

The following are some of simple field test which can be conducted in the field to identify the content of sand and clay for ordinary soil. These two simple tests can help you determine your soil for making mud mortar.

1. Moist cast test. \* Compress moist soil by squeezing it in your hand. When you open your hand, if the soil holds together (that is, forms a cast), pass it from hand to hand — the more durable the cast, the higher the percentage of clay.
2. Ribbon test. \* Roll a handful of moist soil into a cigarette shape and squeeze it between your thumb and forefinger to form the longest and thinnest ribbon possible. Soil with high silt content will form flakes or peel instead of forming a ribbon. The longer and thinner the ribbon, the higher the percentage of clay.

\* For these tests, the soil specimen should be gradually moistened and thoroughly reshaped and squeezed to bring it to its maximum "plasticity" and to remove dry lumps. Do not add too much water, as the sample will lose its cohesion.

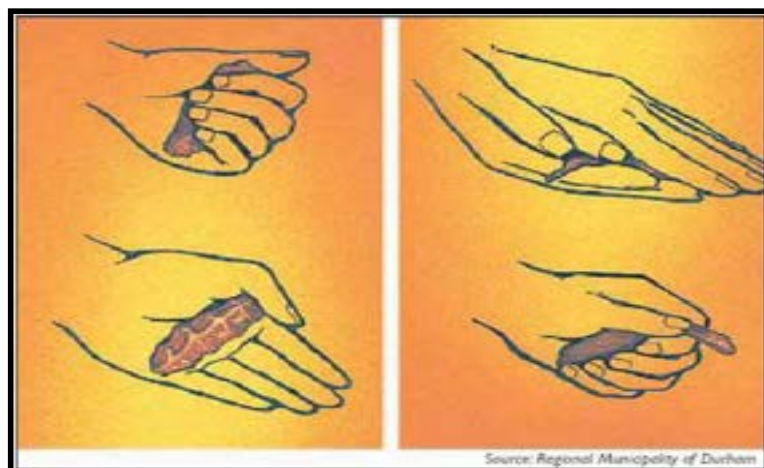

Fig. 6: Testing soil for mud mortar: the moist cast test (left) and the ribbon test (right)

### 3. STONE MASONRY WALLS IN MUD MORTAR

Stone masonry in mud should not be used for community buildings such as schools, hospitals, etc.

#### 3.1 Foundation:

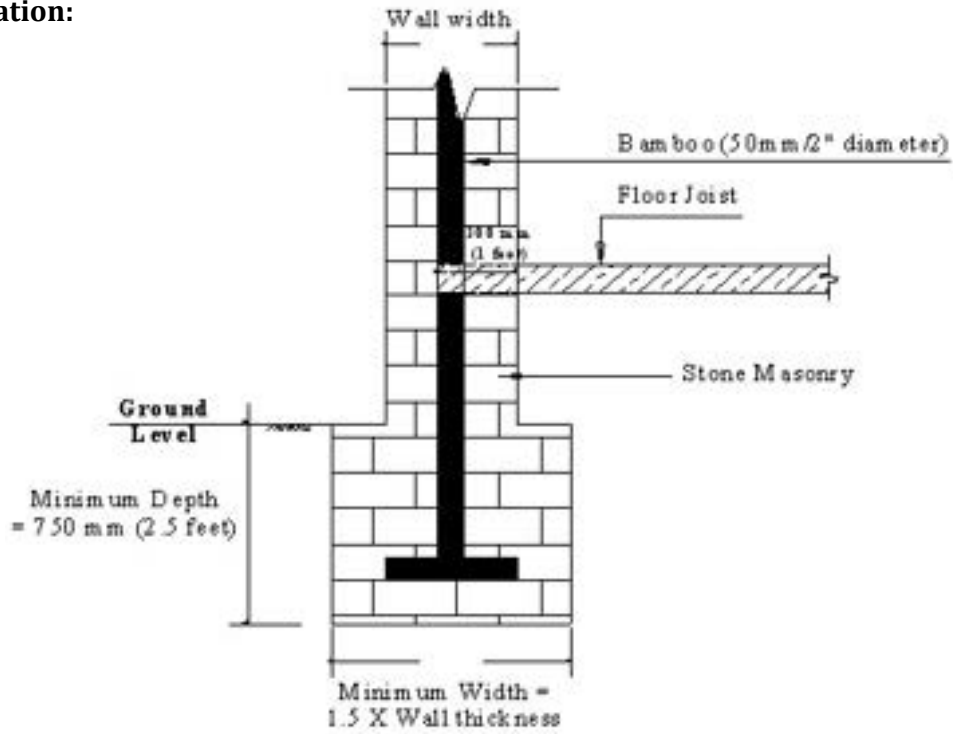

Fig. 7: Foundation Details

#### 3.2 Course work

The masonry should preferably brought to courses at **not more than** 600 mm per lift and thickness of the wall = 450 – 500mm (1.5 – 1.65feet)

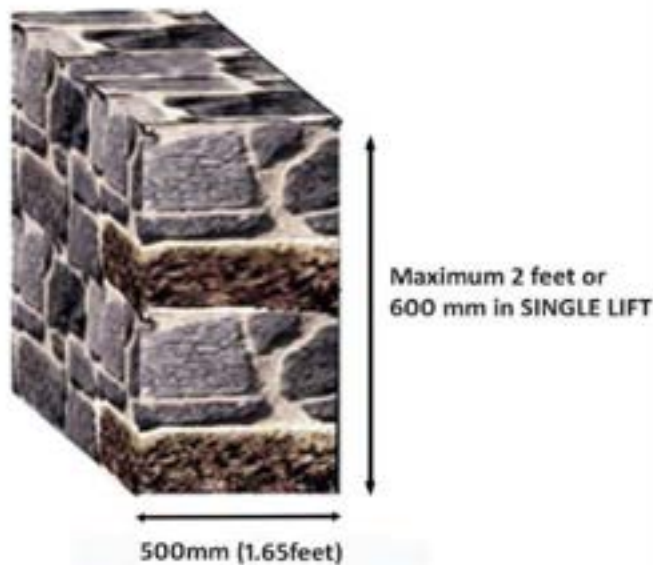

Fig. 8: Maximum height in Single lift and thickness

Long stones to be used at corners and joints to break the vertical joints and to provide bonding between perpendicular walls

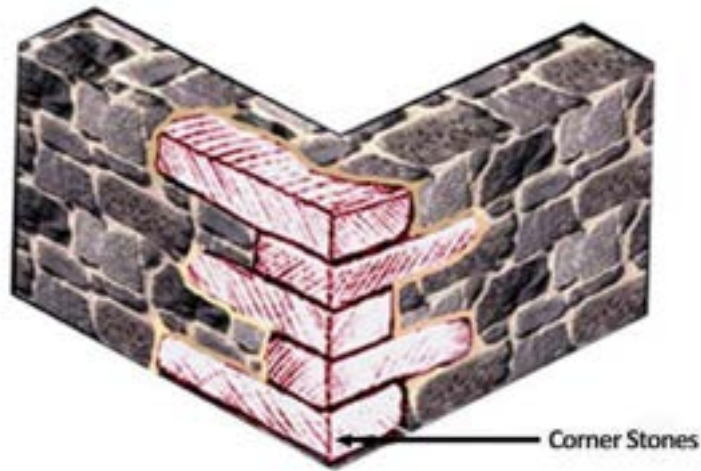

Fig. 9: Corner Stones

### 3.3 Through Stones Details

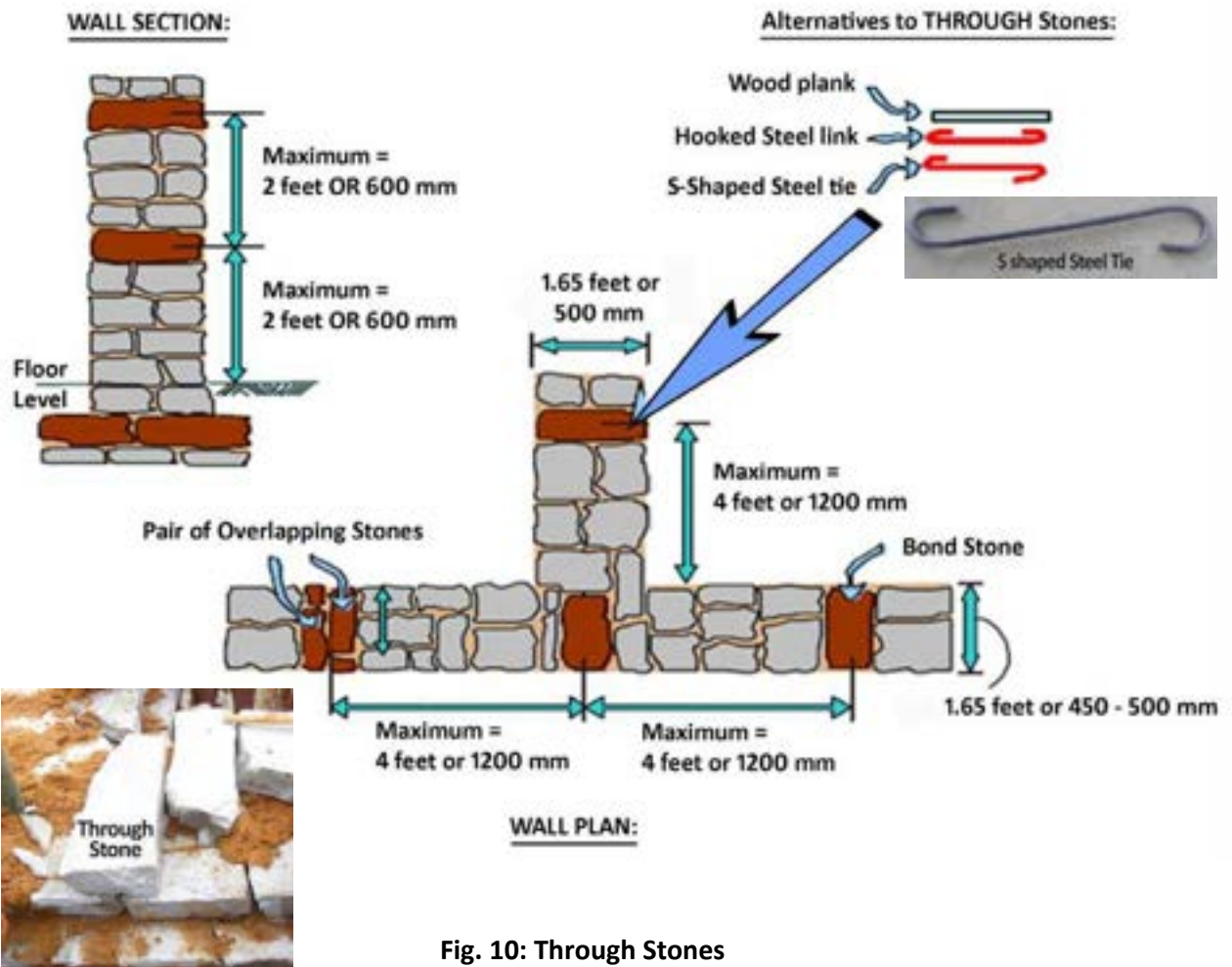
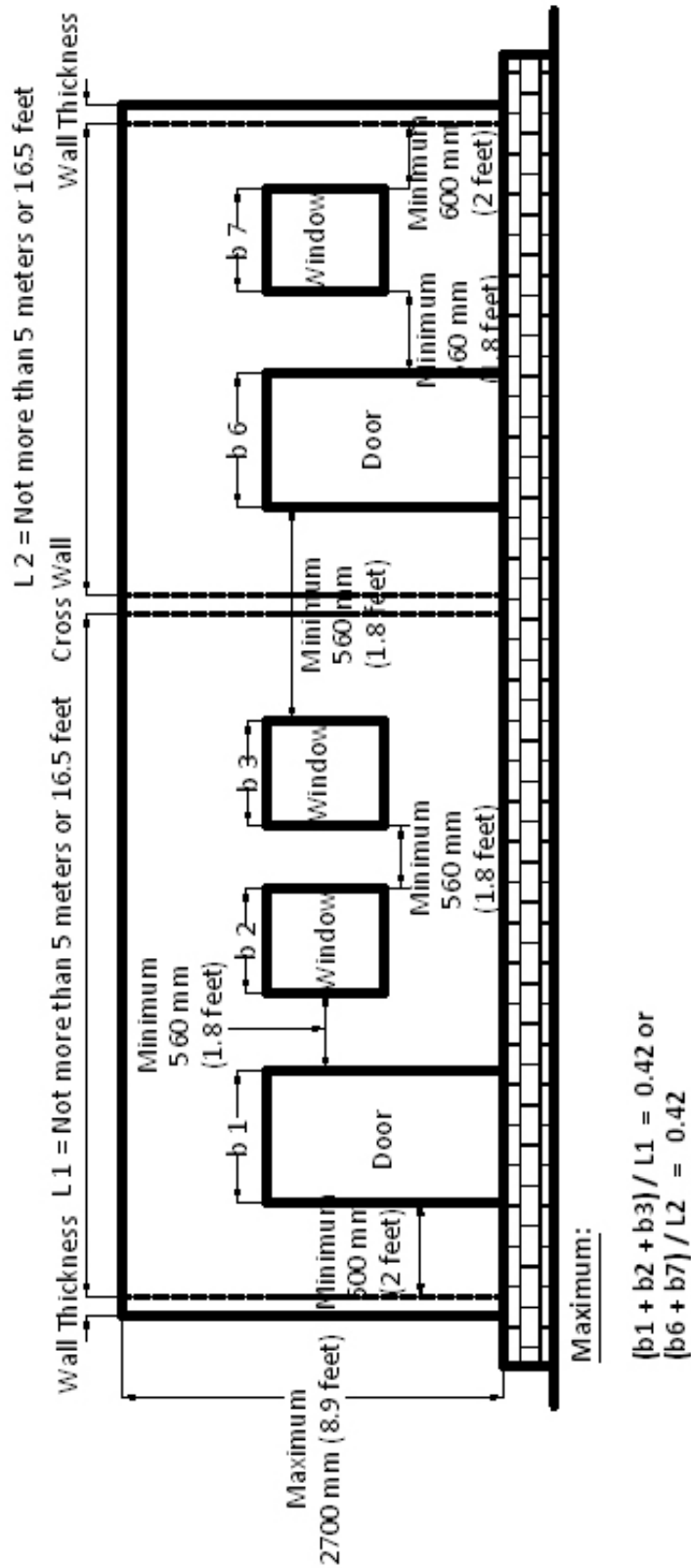

Fig. 10: Through Stones

### 3.4 Opening in Walls

Fig. 11: Dimensions of Openings



### 3.5 Control on Wall length and Building Height

Height of the Stone masonry walls should be restricted as follows:

- a. Ceiling height = Maximum 2700 mm or 8.9 feet;
- b. Span of walls between cross walls = Maximum of 5000 mm or 16.5 feet;

Number of Storeys:

- a. Maximum of **1 storey** if walls are built with lime sand or mud mortar;

**Fig 12: Control on length, height and walls in Stone Masonry**

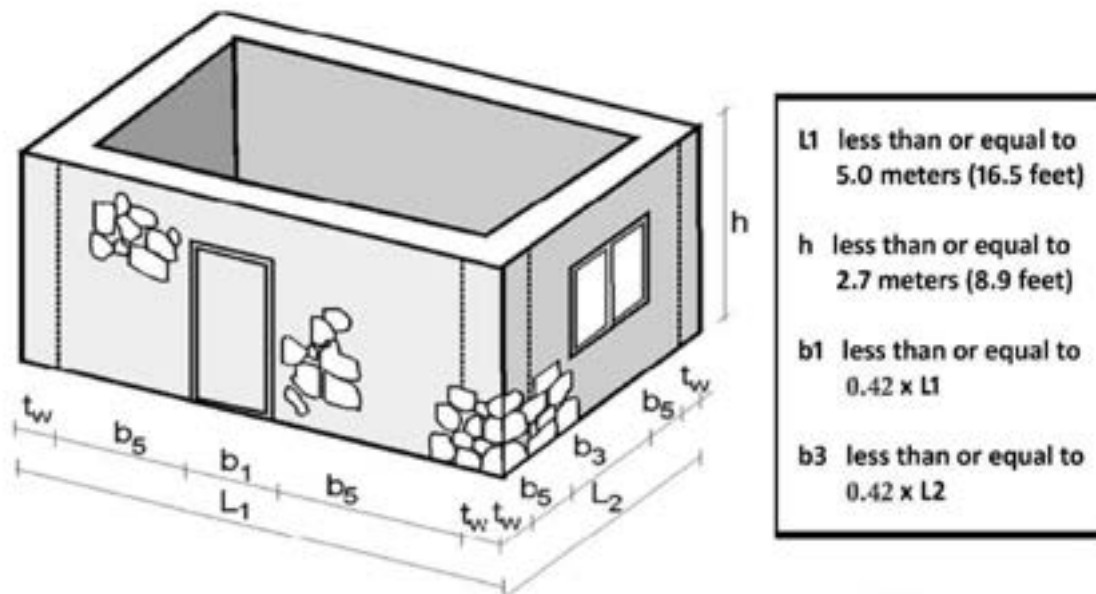

### 3.6 Arrangement of Earthquake resistant elements in single Storey house

Fig. 13: Provision of Horizontal bands in single storey house

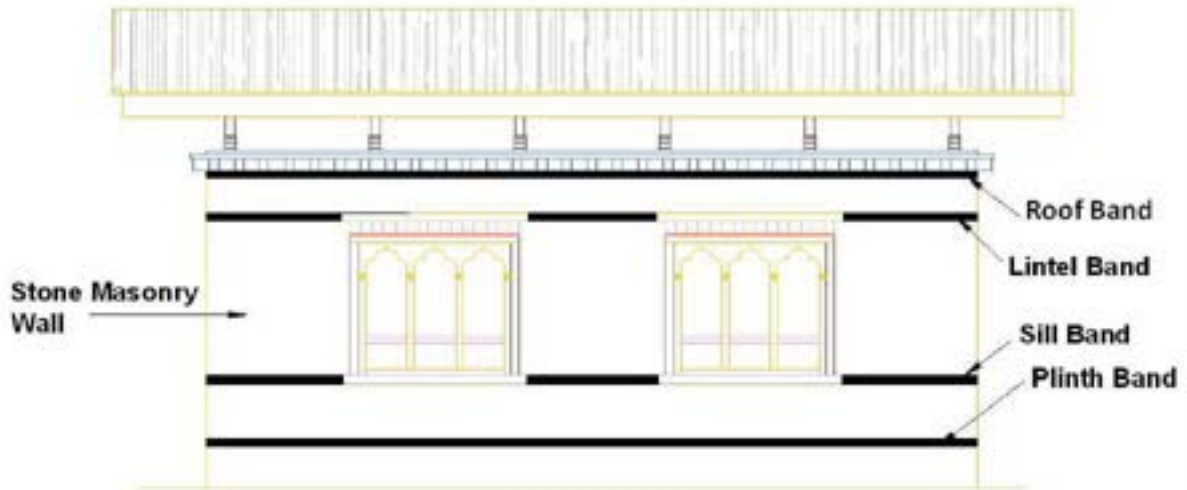

#### 3.6.1 Horizontal Bands in walls

**a. Horizontal Band or Ring beams to be provided at sill, lintel**

Horizontal band made of timber with two longitudinal runners of 75mm x 38mm (3" by 1.5") with splice of 50mm x 30mm (2" by 1.2") spaced at 500mm (1.6 feet) c/c. The timber bands will have to painted with anti termite paints and right choice of timber is to be used to prevent from decaying and termite attack.

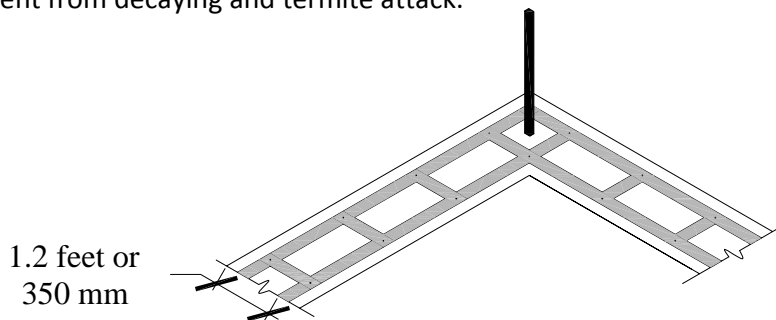

Timber Band at Plinth and Lintel level

Fig. 14: Band at Corners and intersection

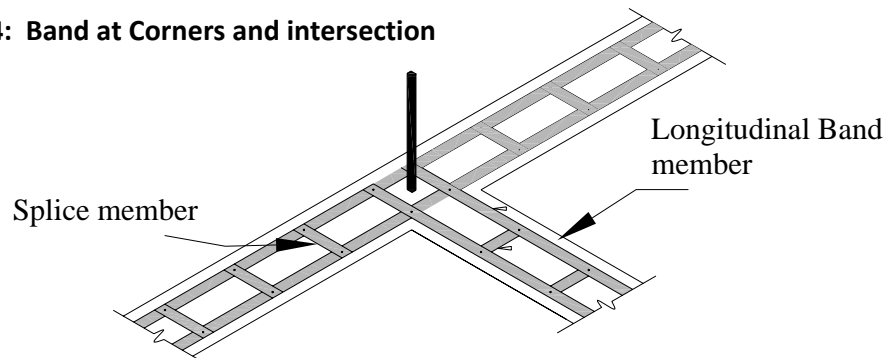



Fig. 15: Vertical and Horizontal Bands

Fig. 16: Timber Band details

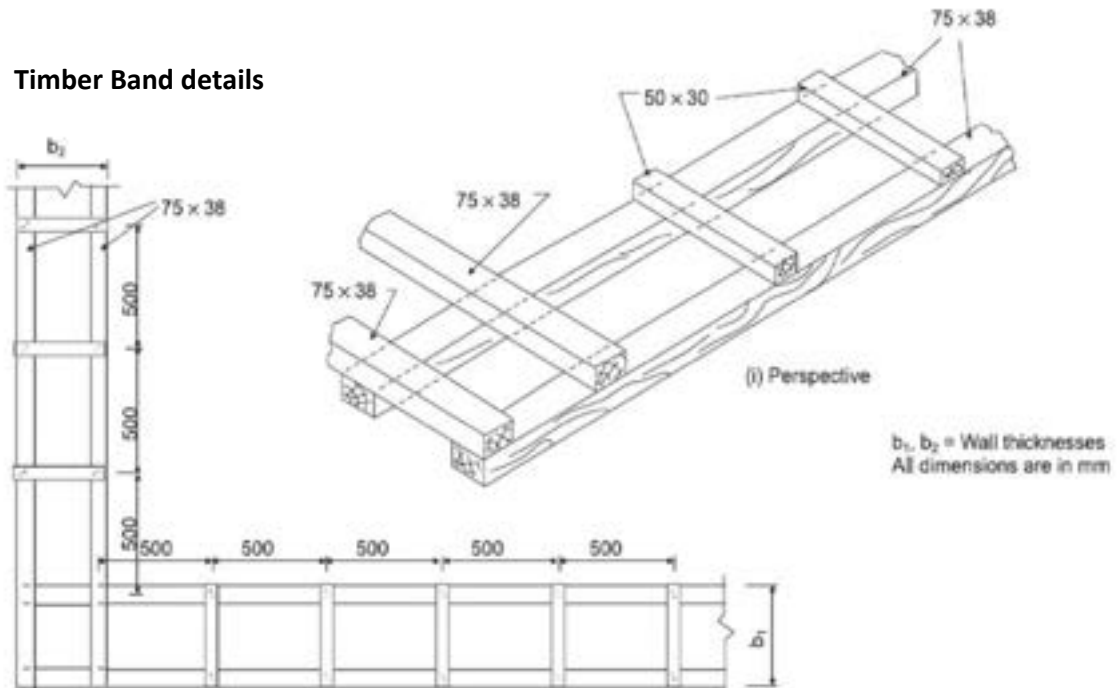
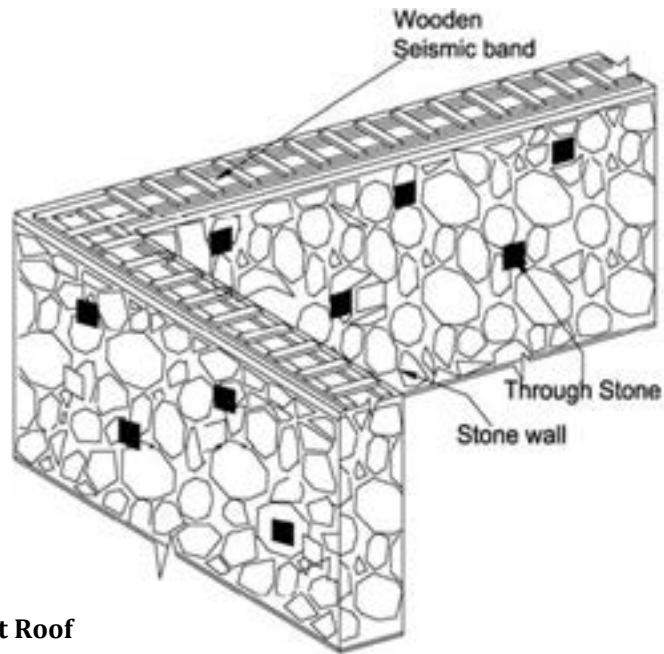

Fig. 15: Band at Intersection

**Fig. 17: Isometric view of Timber band on stone masonry building**



### 3.6.2 Horizontal Band at Roof

Timber plank 300 mm x 35 mm thick (1' by 1.4" thick) to be provided on top of wall at roof level.

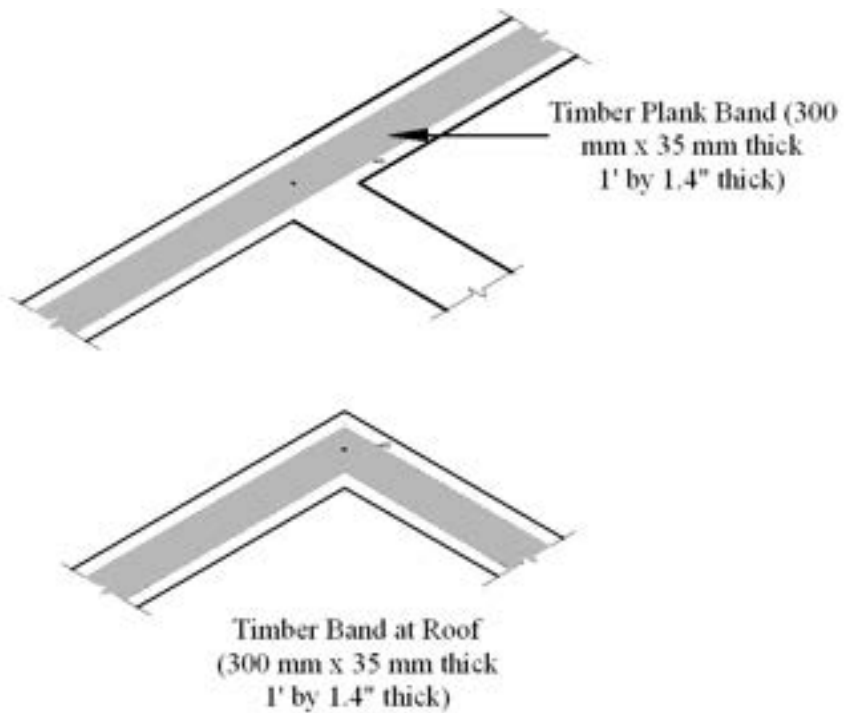

**Fig. 18: Roof Bands**



### 3.7 Vertical Reinforcement in walls

#### Alternative 1:

- a. Bamboo reinforcement: 50 mm diameter bamboo rebar provided at wall corners, intersection corners and intersection of windows and doors openings. The rebar is firmly anchored in the foundation and goes right up till the roof level. The bamboo may be wrapped in plastic sheet to prevent from decaying.

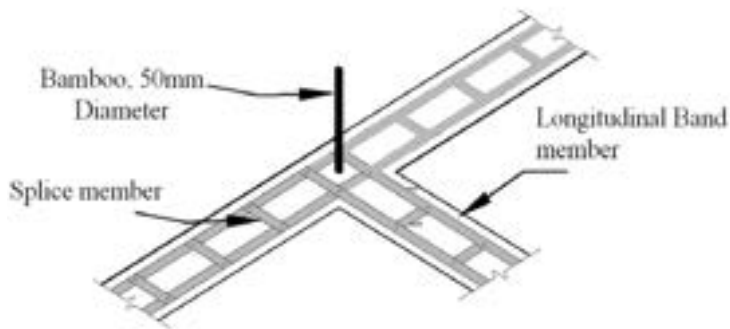

Fig. 19: At Intersection

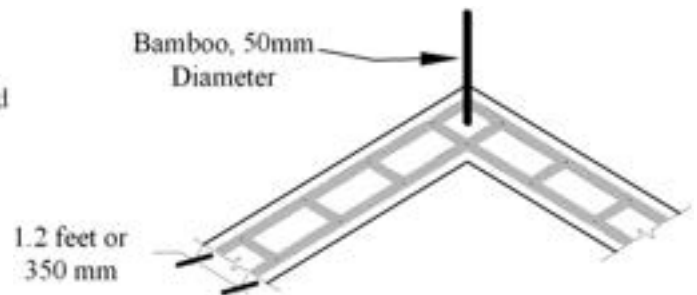

Fig. 20: At Corners



Fig. 20: At Corners and intersections

**Alternative 2:**

- b. Timber Reinforcement:** 50mm x 50mm wooden post at wall corners and intersection fixed with metal strap and nails to the wall, extending all through the building height, firmly anchored in the foundation. A single unit wooden post to be used as far as possible. However if joint is necessary dovetail joint as shown in the figure to be used.

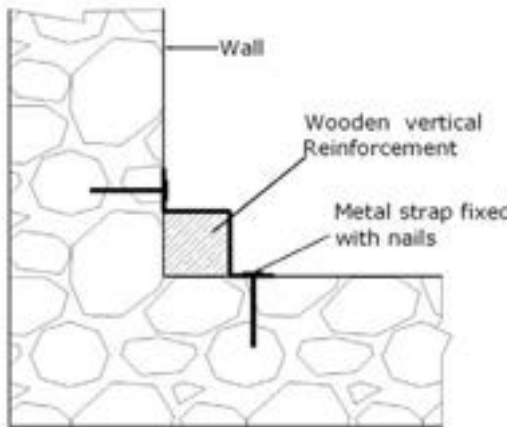

**Fig. 21: Vertical Reinforcement at Corner**

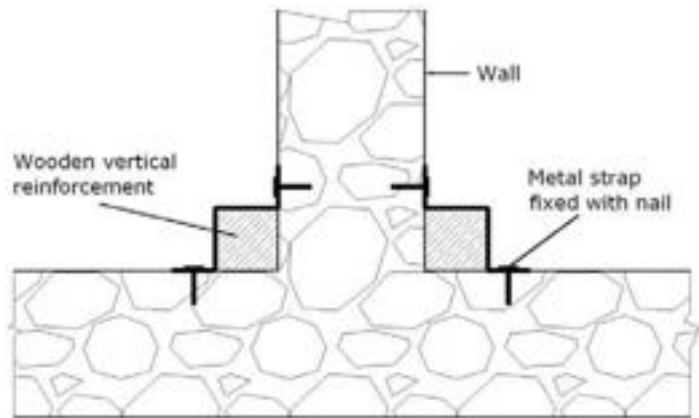

**Fig. 22: Vertical Reinforcement at intersection**

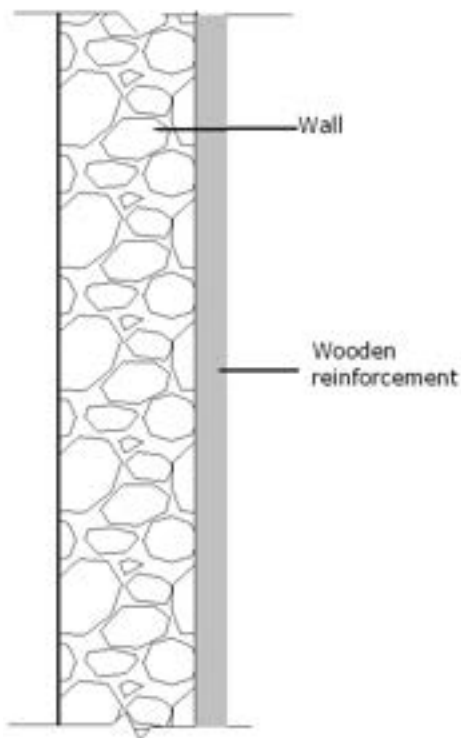

**Fig. 23: Section**

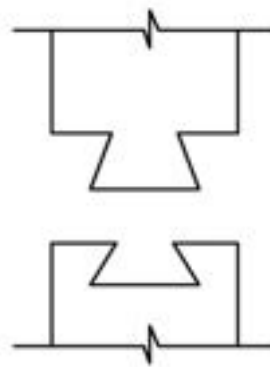

**Fig. 24: Dovetail joint**



Alternative 3:

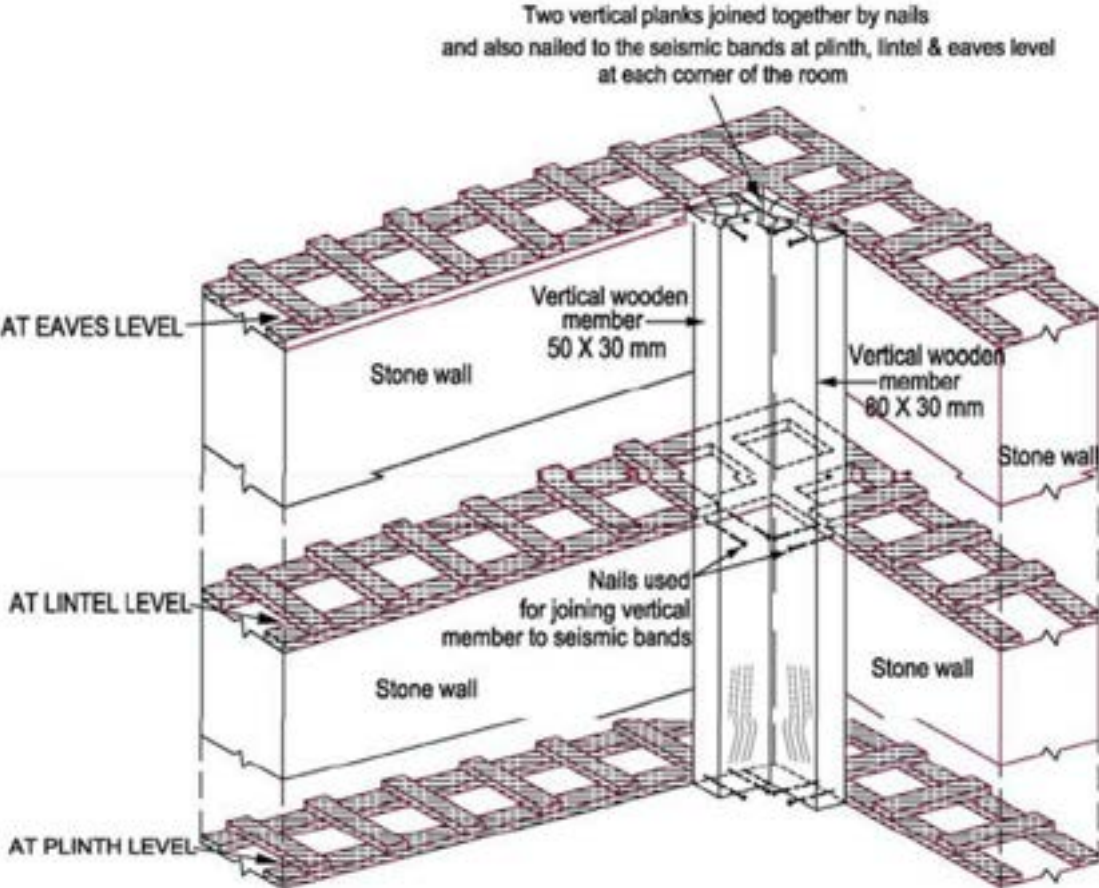

Fig. 25: Vertical Reinforcement at Corner and Intersections

4. STONE MASONRY WALLS USING CEMENT MORTAR

4.1 Foundation:

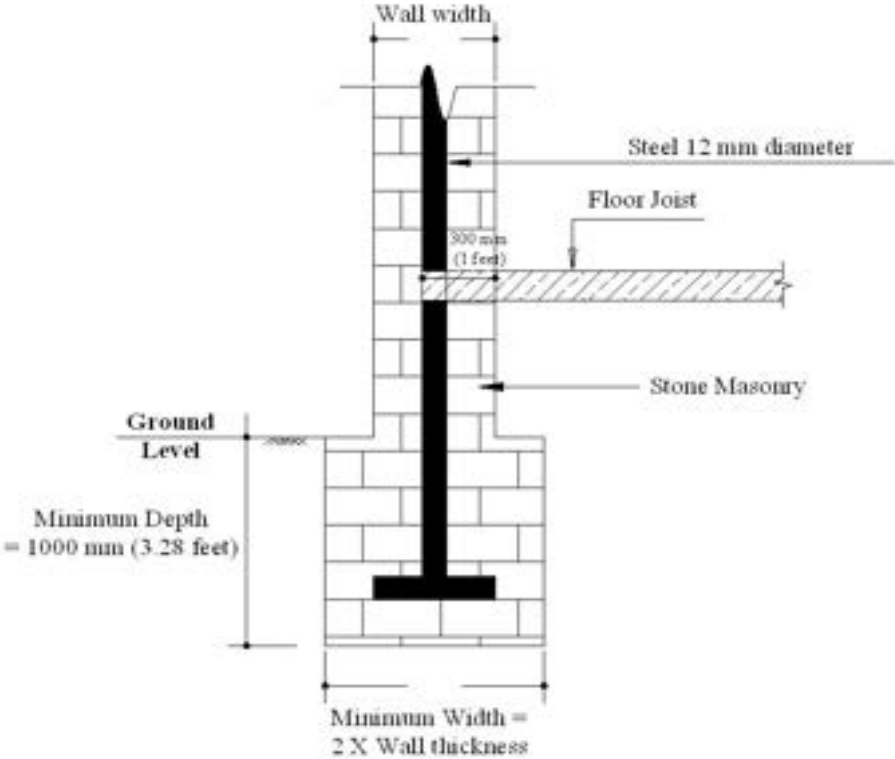

Fig. 26: Foundation Details

4.2 Course work

The masonry should preferably brought to courses at not more than 600 mm per lift and thickness of the wall = about 400mm (1.3 feet)

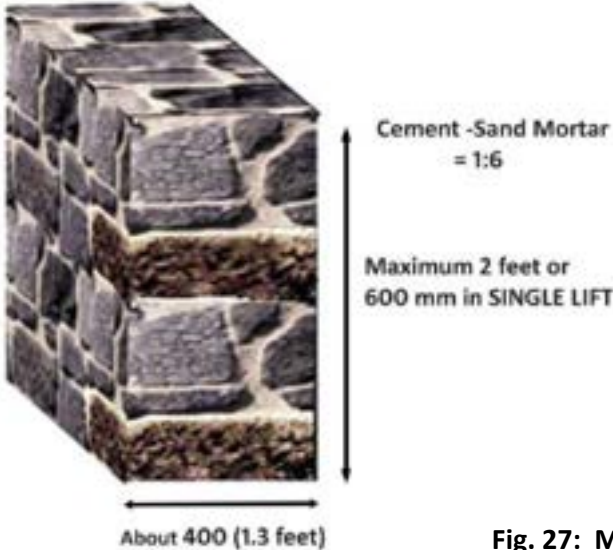

Fig. 27: Maximum height in Single lift

Long stones to be used at corners and joints to break the vertical joints and to provide bonding between perpendicular walls.

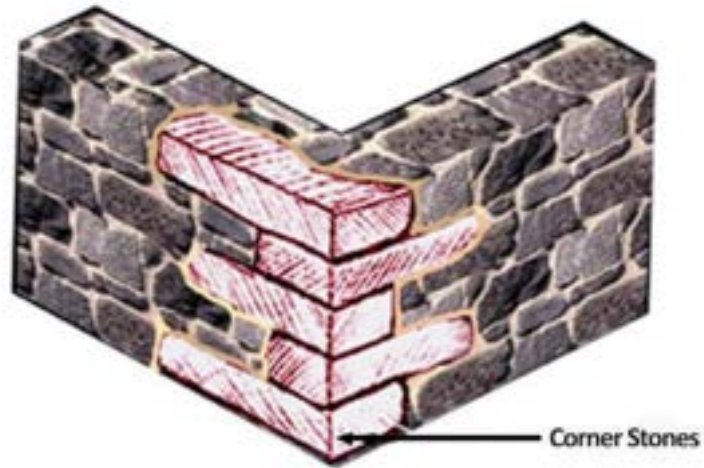

Fig. 28: Corner Stones

### 4.3 Through stones

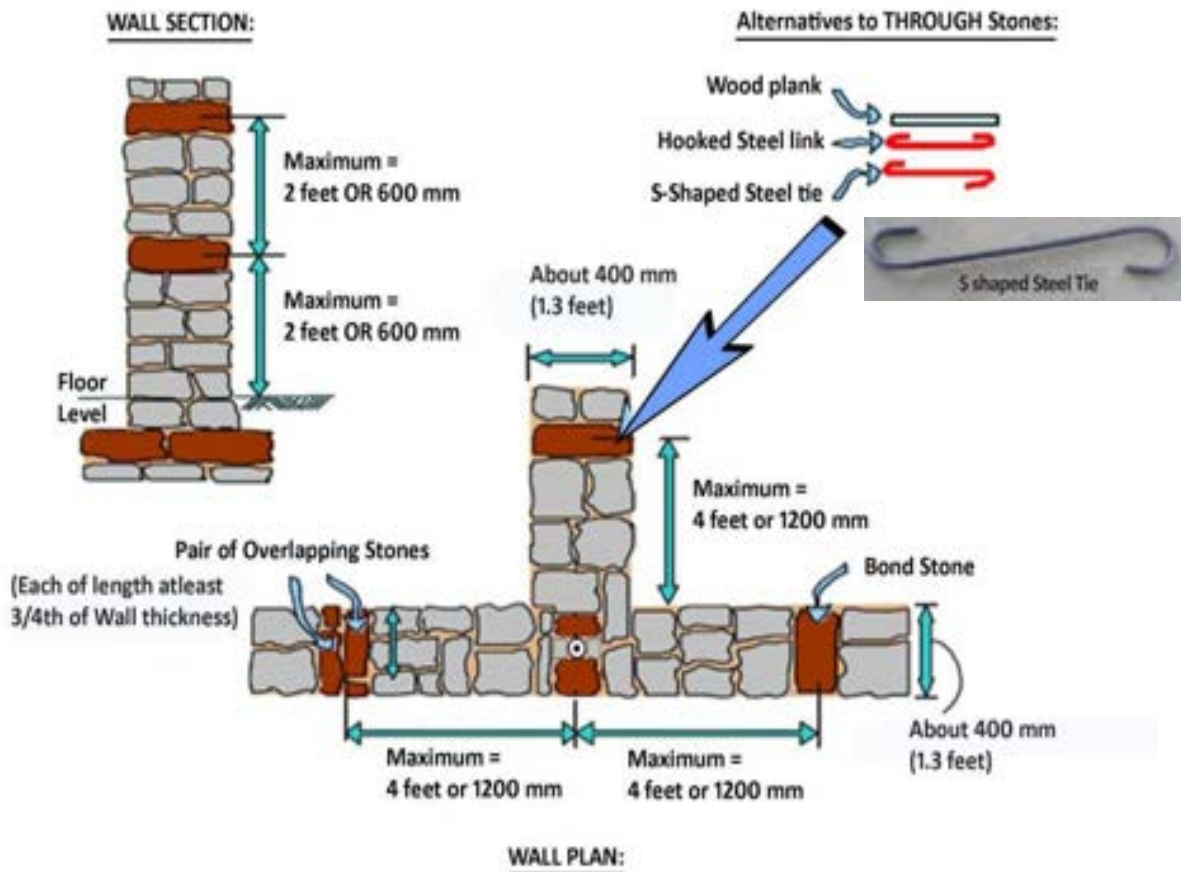

Fig. 29: Through stones details

#### 4.4 Control on Wall Length and Building Height

Height

The height of the coursed-rubble masonry walls in cement mortar should be restricted as follows:

- ✓ Two storey;

The ceiling height to be kept 3000 mm (9.8 feet) maximum and span of walls between cross walls to be limited to 5000 mm (16.4 feet).

**Fig. 30: Control on length, height and walls in Stone Masonry**

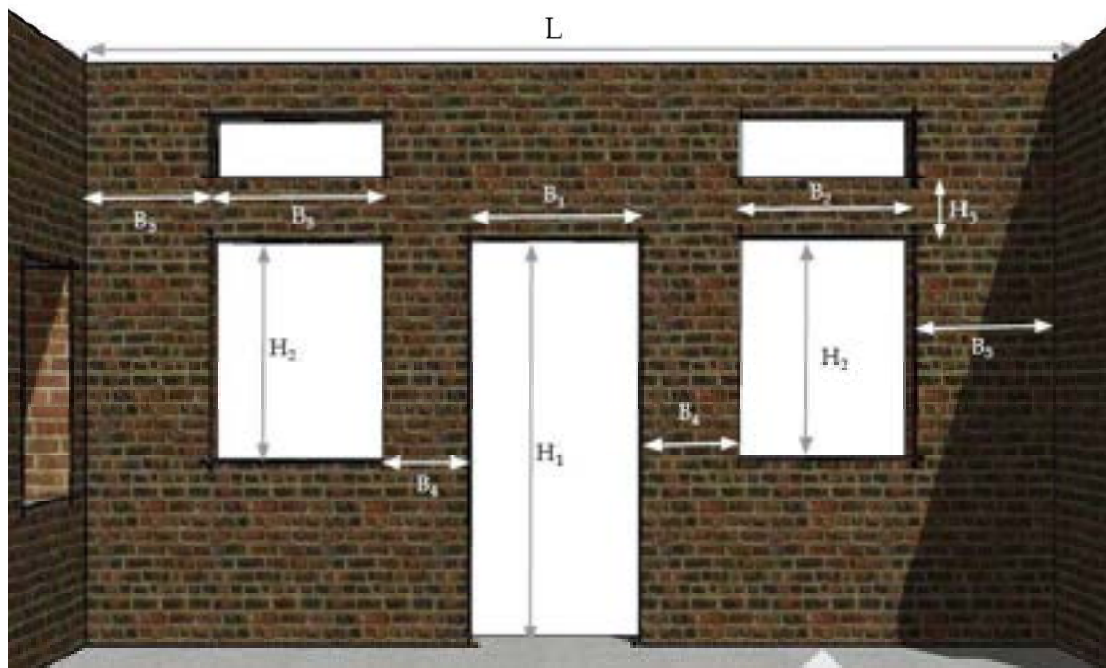

(Total length of openings in a wall) / (length of the wall in a room) **should not exceed:**

Example:  $(B_1 + B_2 + B_3) / L$

- = 0.55 in single storey
- = 0.42 in 2-storey

1. Distance of opening from inside corner ( $B_5$ ) **more than or equal** to 450mm (1.5 feet)
2. Pier width between consecutive openings ( $B_4$ ) **more than or equal** to 600mm (2 feet)

4.5 Horizontal Bands in walls with recommended layout of the building.

Fig. 31: Recommended layout of the building with location of Horizontal bands

Building Type 1:

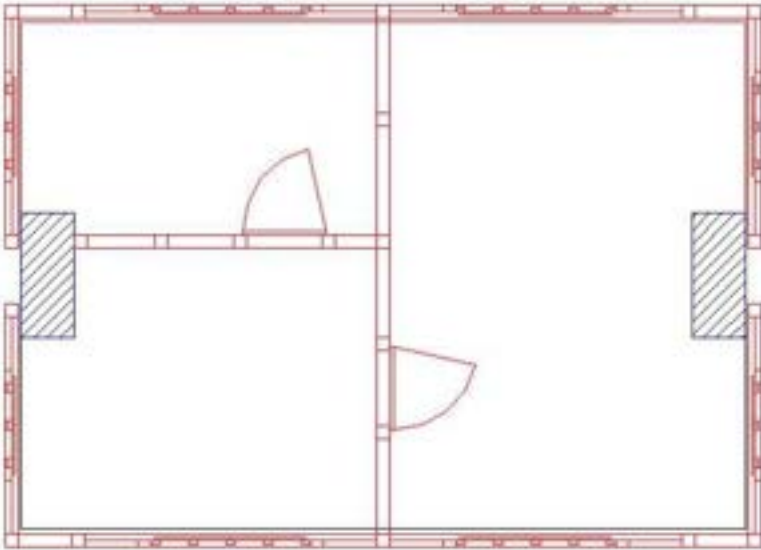

**FIRST FLOOR PLAN**

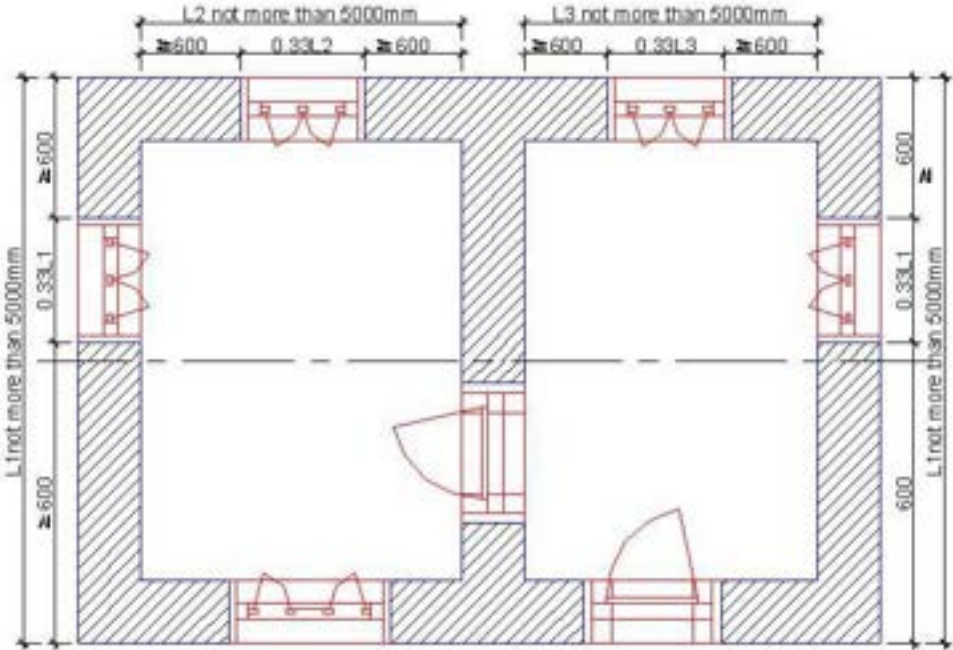

**GROUND FLOOR PLAN**

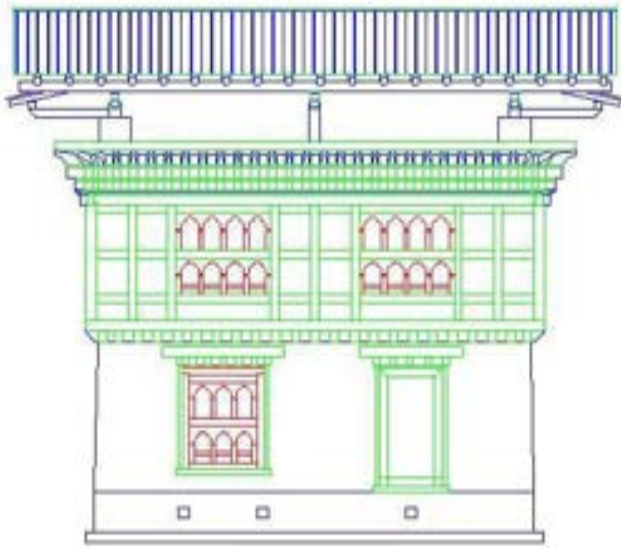

**FRONT ELEVATION**

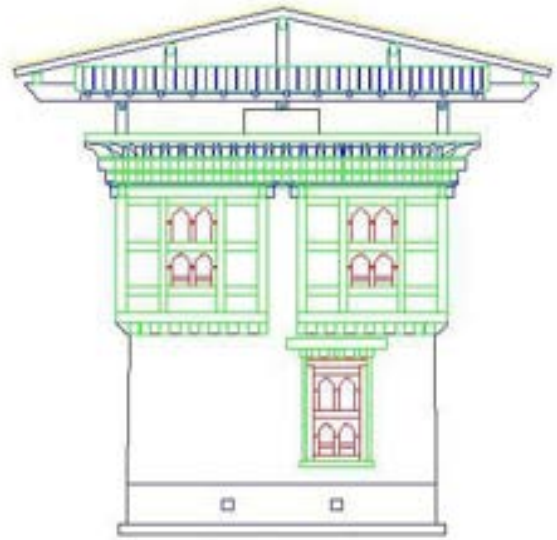

**SIDE ELEVATION**

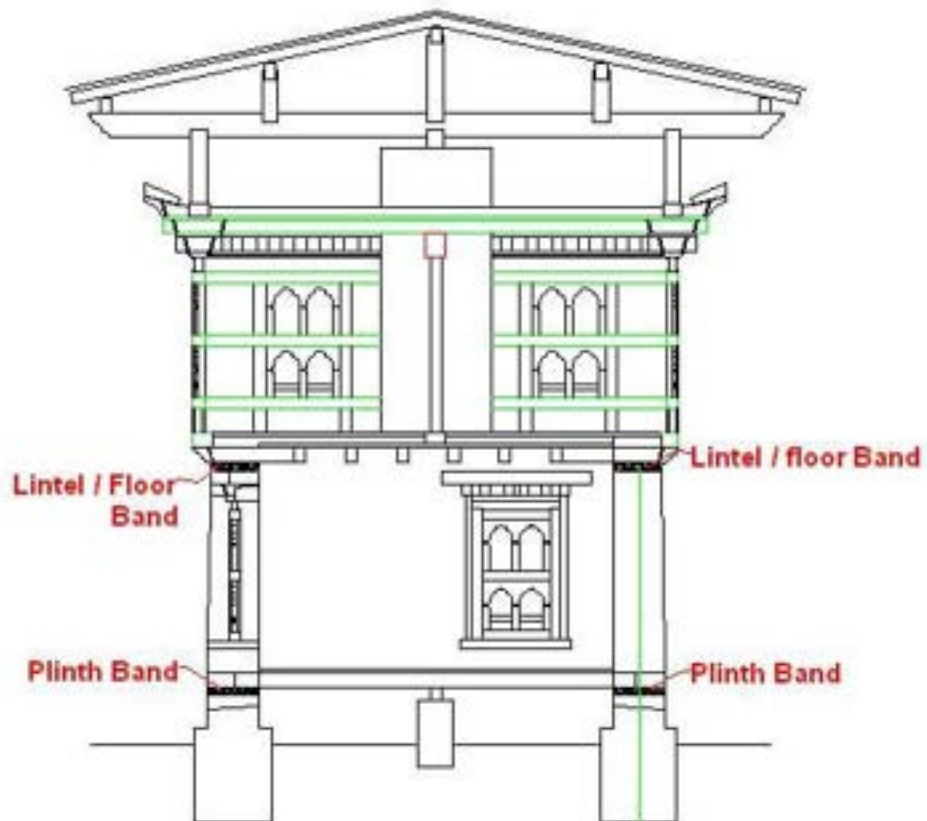

**SECTION showing the Bands location**



**Building Type 2:**

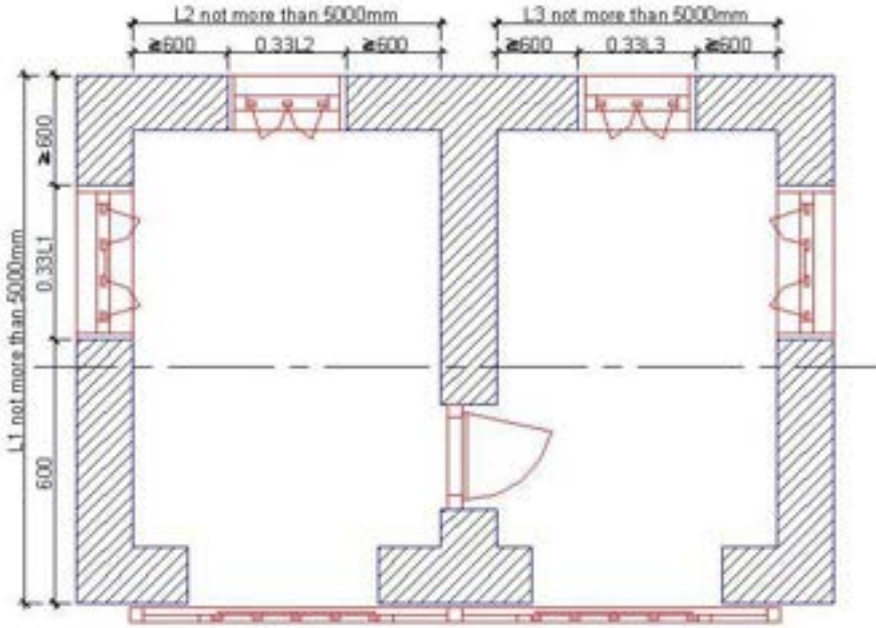

**FIRST FLOOR PLAN**

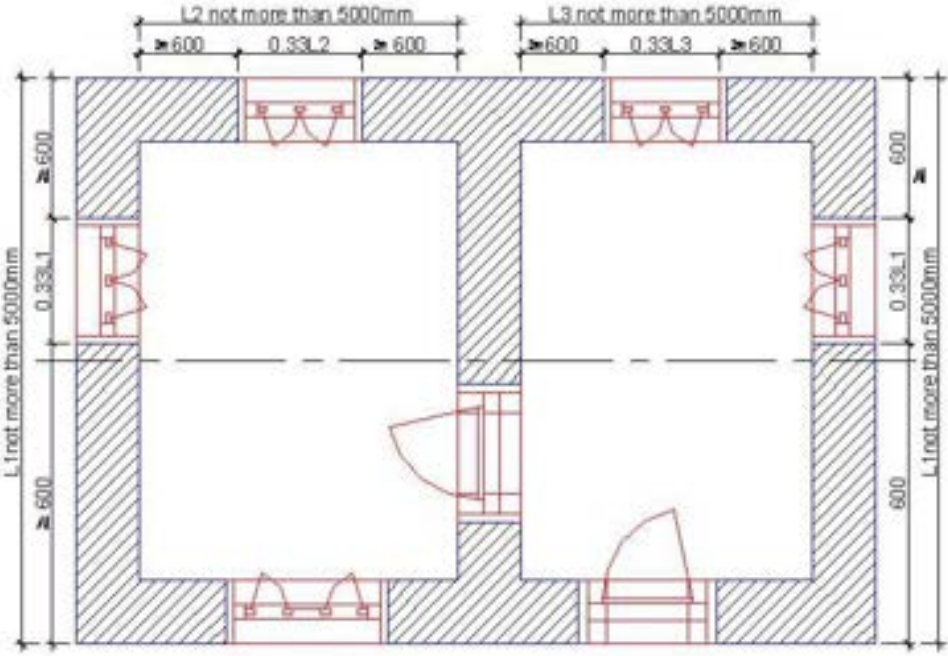

**GROUND FLOOR PLAN**

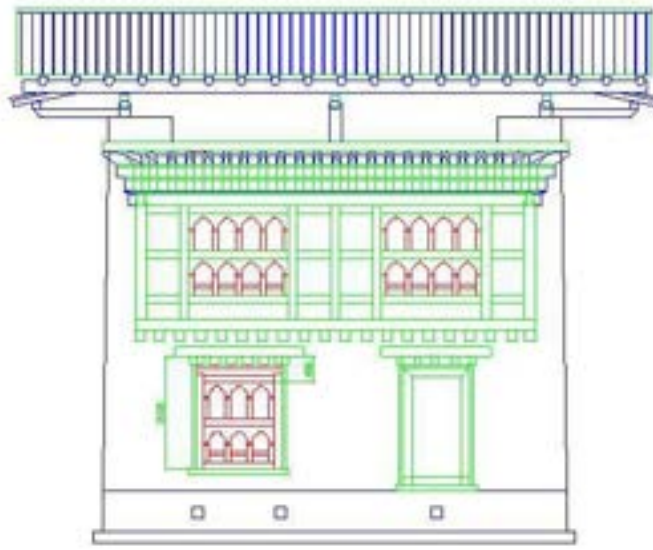

**FRONT ELEVATION**

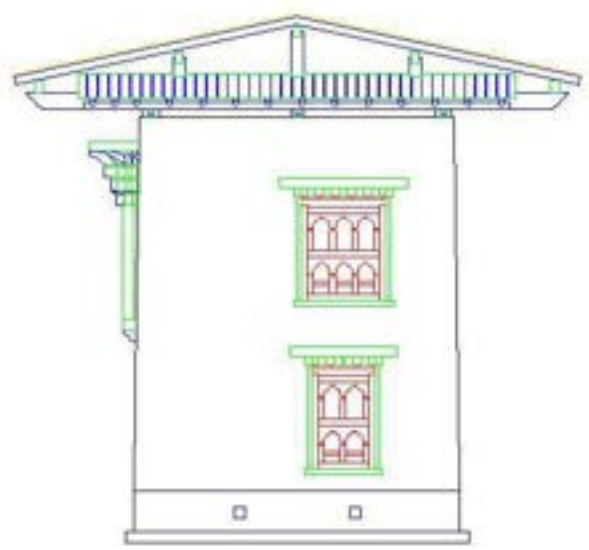

**SIDE ELEVATION**

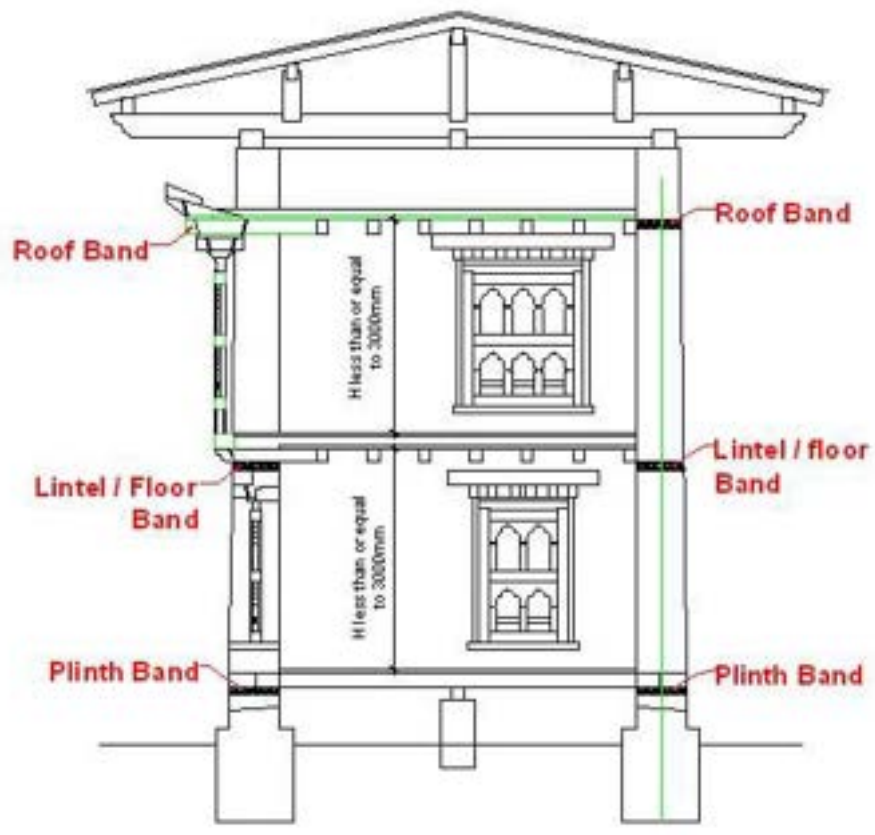

**SECTION showing the Bands location**

**Building Type 3:**

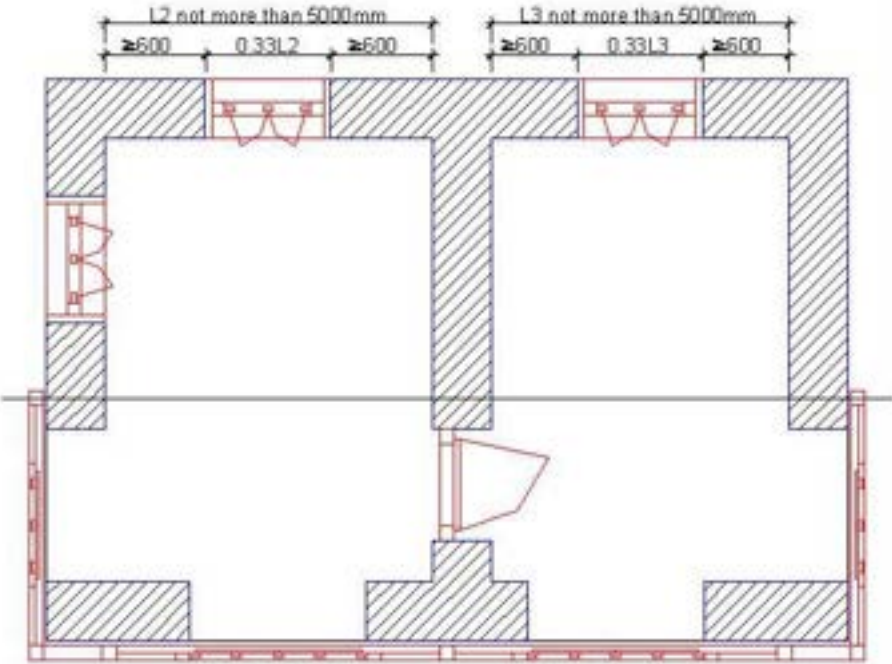

**FIRST FLOOR PLAN**

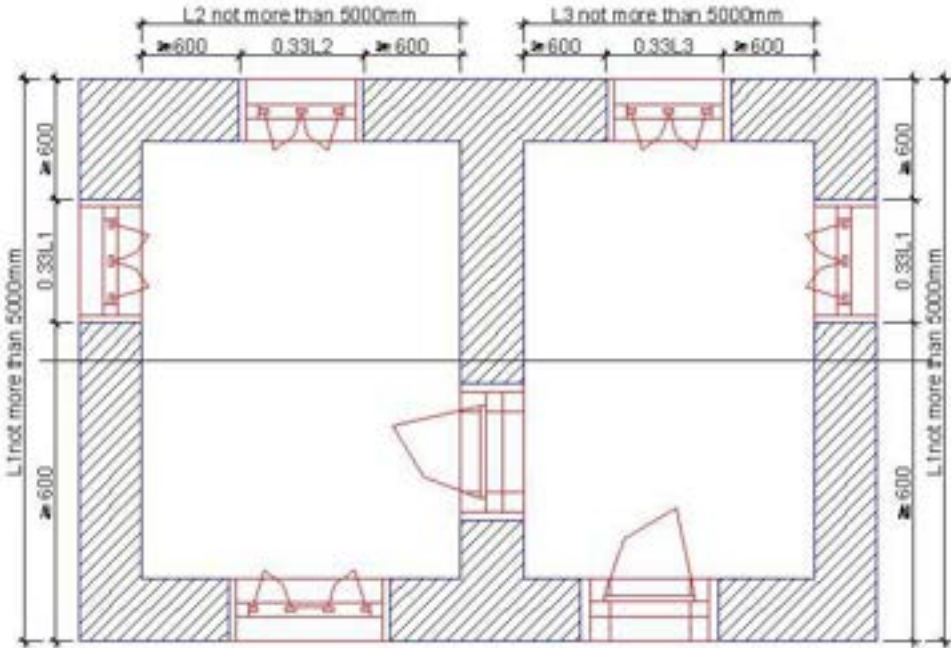

**GROUND FLOOR PLAN**



**FRONT ELEVATION**

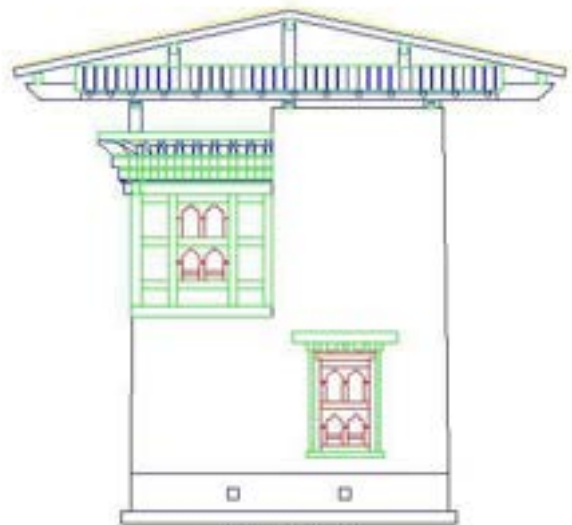

**SIDE ELEVATION**

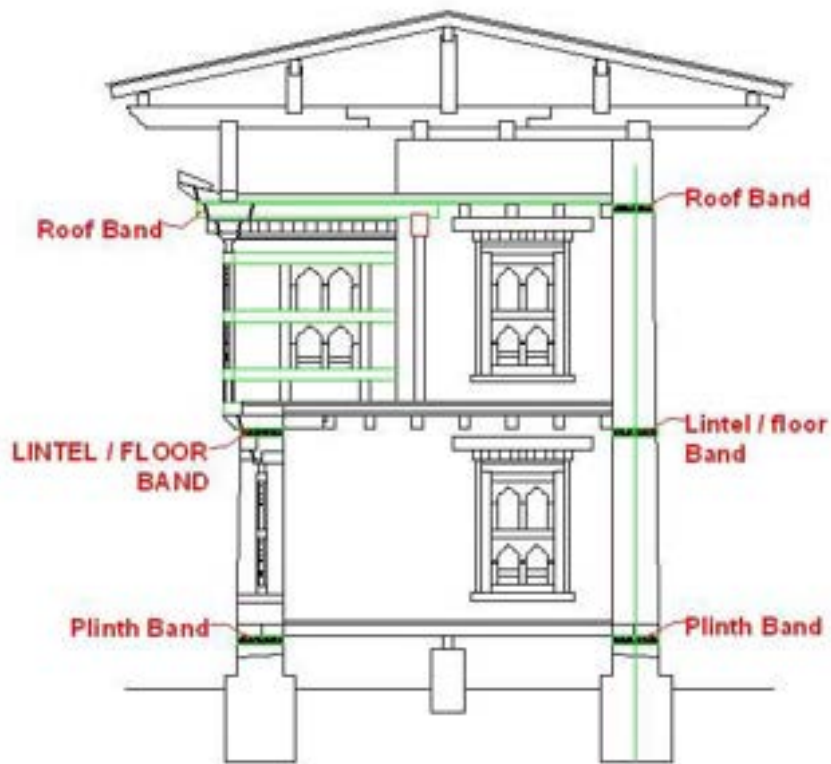

**SECTION showing the Bands location**

**Fig. 32: Reinforcement & Bending detail in Reinforced Concrete Band**

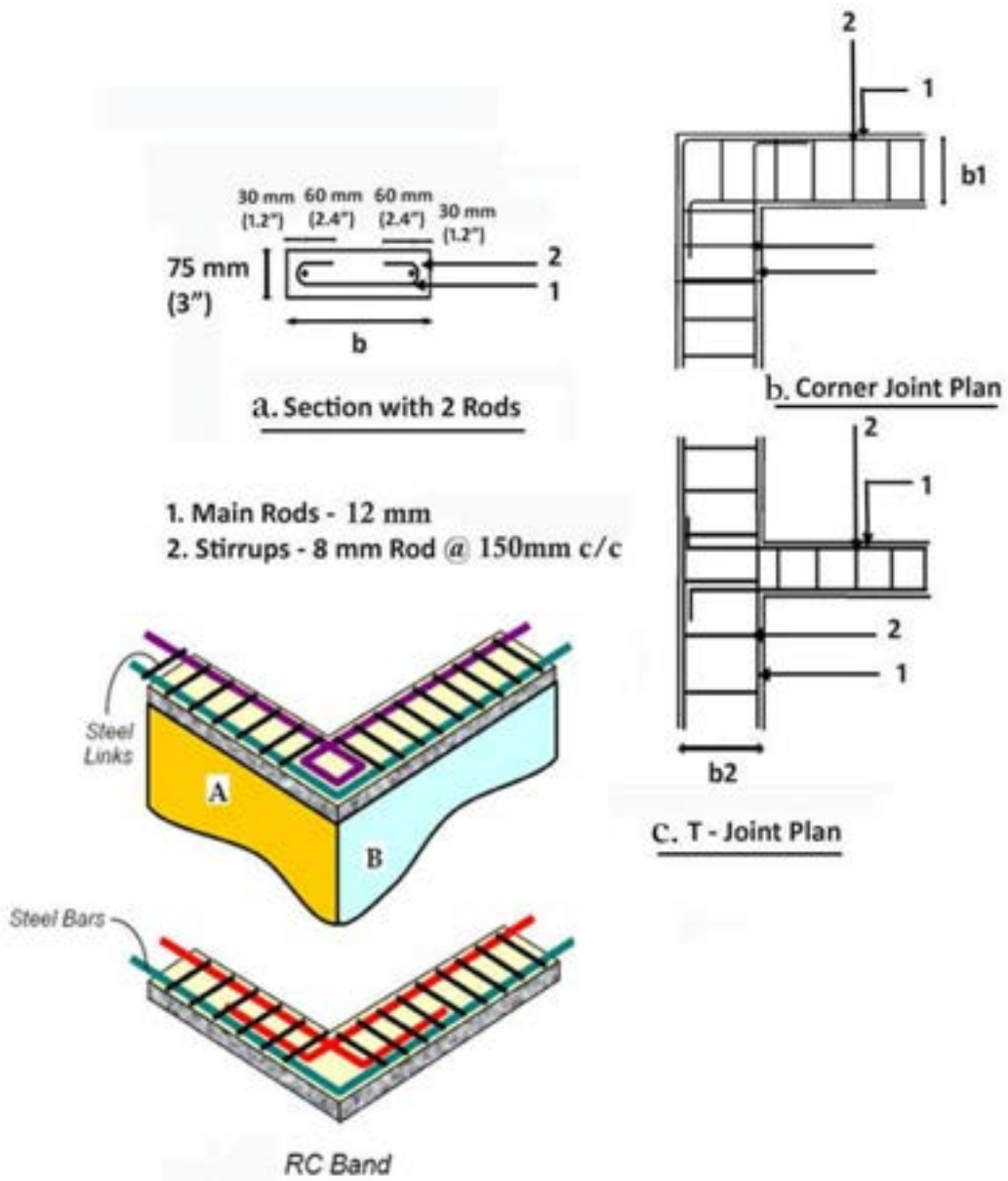

**Table 1: Longitudinal rods in RC Bands**

Length of wall in room (m)	Number of Storey	Diameter (mm)
Less than or equal to 5m or 16.4 feet	2	12
6m or 19.7 feet	2	12



el Rod 12mm

Steel Band

**Fig. 33: Steel in Reinforced Concrete Band**



**Fig. 34: Reinforced Concrete Band**

**4.6 Truss to Band connection –**

**4.6.1 Alternative 1**

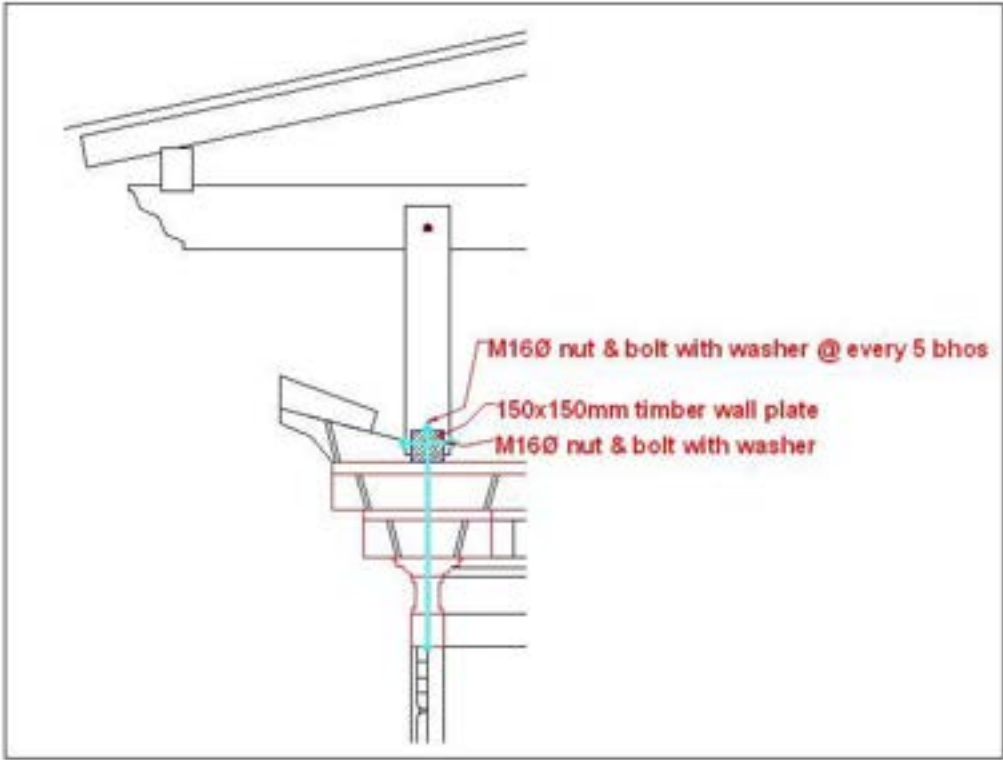

**4.6.2 Alternative 2**

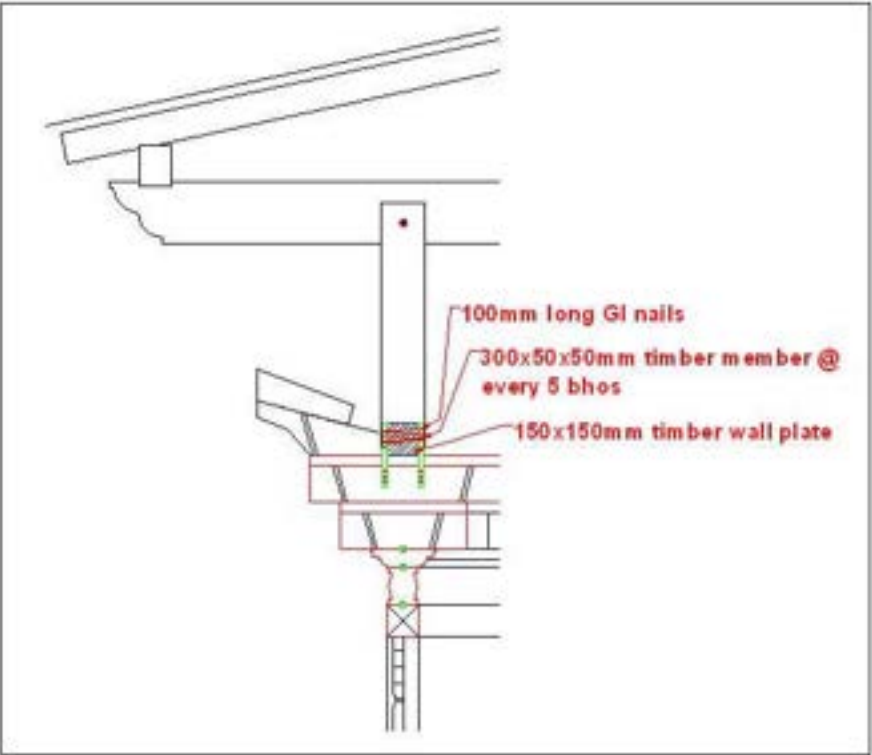

## 4.7 Vertical reinforcing rods in walls

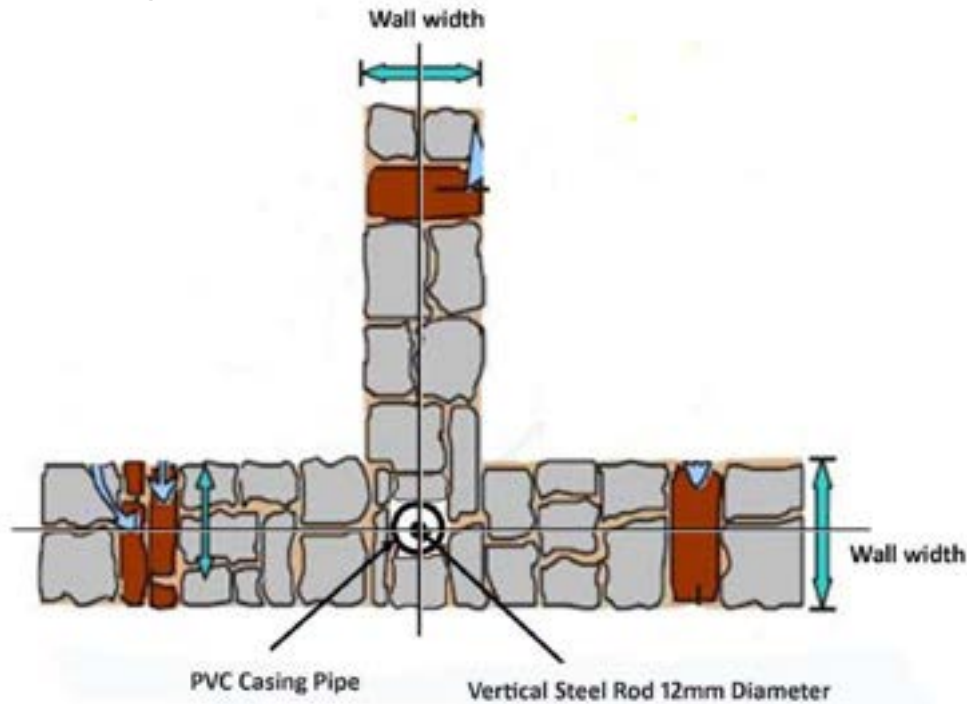

**Fig. 35: Vertical Rods:**

### 4.7.1 Installation of Vertical Bars:

For installations of vertical bars in stone masonry, use of PVC casing pipe of 100mm external diameter, 600-750 mm long is recommended around which masonry be built to height 450-600mm and the pipe made loose by gently rotating. As the masonry hardens, the pipe is raised and the cavity filled with M20 concrete (nominal mix of 1:1.5:3) and fully compacted by rodding using 12mm diameter and 600mm long bar.

#### **Note:**

1. The vertical steel rods should be covered with concrete of M15 grade (1:2:4) or with mortar 1:3 (Cement-Sand) in suitable pockets around the bars;

#### **1. Keeping the Bar Vertical**

Before casting the foundation, the vertical bars must be kept in correct in position horizontally and vertically. For this purpose tripods may be erected using bamboos or spare reinforcing bars.

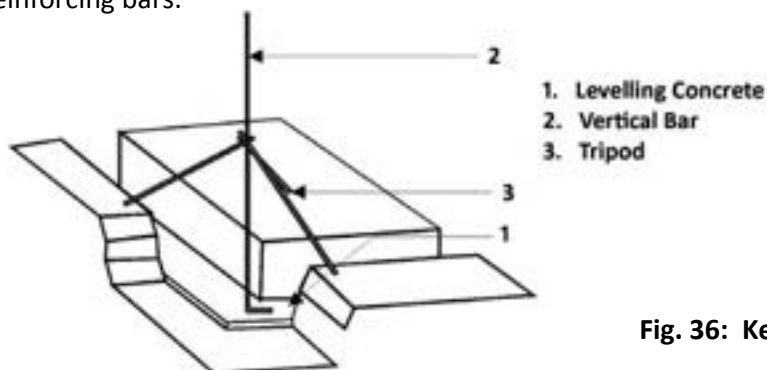

**Fig. 36: Keeping the Steel rod vertical**



## 5. EARTHQUAKE SAFETY TIPS

### 5.1 Before an Earthquake

- Ensure that your home is safe. While constructing new buildings, ensure that your building complies with building and seismic codes.
- Teach family members how to turn off electricity, gas and electric supply at the main sources
- Practice *DUCK, COVER & HOLD*. Duck under a sturdy desk or table, hold on, and protect your eyes by pressing your face against your arm. If there's no table or desk nearby, sit on the floor against an interior wall.



Ducking in an open doorway, covering the head (with one hand) and holding onto the doorway



Ducking in the corner of a supporting wall, covering the head and holding on, if possible



Ducking under a table, covering the head and holding onto a table leg.

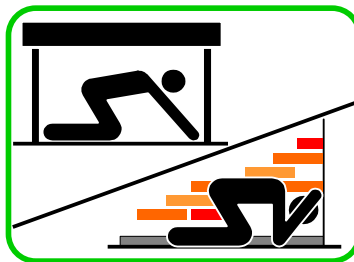
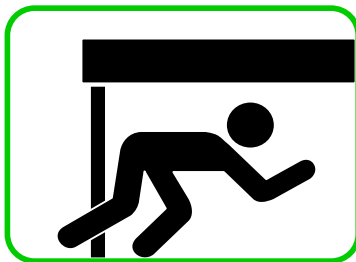

- Keep list of important telephone numbers to be contacted in case of emergency
- Identify likely hazards in and around your school/home/residence. For eg shelves and heavy objects that may fall during an earthquake, hallways and stairways that may get blocked during an earthquake.
- Convert hazards, wherever possible. For eg: strapping of heavy furniture/cabinets to the wall to prevent toppling, identifying alternative route to leave the room or building.
- Prepare a first aid kit, including basic emergency items e g: torches, batteries etc.

## 5.2 During an Earthquake

### If Indoors



If you are in a structurally sound building, stay there.



If you are inside an old weak structure, take the fastest and safest way out.



If you are **near an exit**, leave the building as soon as possible.



After the shaking stops, take the staircase to reach open space.

- Do not exit the building during the shaking.
- Duck, cover and hold.
- Face away from windows as the panes may shatter because of the tremor.
- Count aloud to 60 seconds earthquakes usually lasts no longer than 60 seconds and counting would have a calming effect.
- As soon as the shaking stops take safest and fastest exit out of the building.
- In case if students, do not rush to the exit, get out calmly in an orderly manner.
- Do not enter the building as aftershocks may cause parts of the building to collapse.
- If you are in a crowded store or other public place, do not rush for exits. Move away from display shelves containing objects that could fall.

### If Outdoors

- If you are outside, move to an open area.
- Stay away from power lines, posts, walls and other structures that may fall or collapse.
- If you are driving a vehicle, pull to the side of the road and stop.
- Don not attempt to cross bridges or overpasses which may have been damaged.

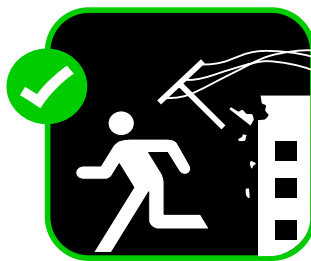

Move away from power lines, posts, walls, false ceiling, parapet, falling flower pots and other elements that may fall or collapse.



Stay away from buildings with glass panes.



If you are on a steep hillside, move away in case of landslides and falling rocks.

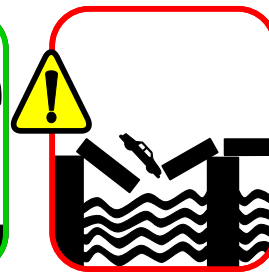

When driving a vehicle pull to the side of the road and stop. Do not attempt to cross bridges damaged.

### **5.3 After an Earthquake**

- STAY CALM!
- Check yourself for injuries.
- Give first aid as necessary. Help people near you if they are injured.
- Move cautiously, and check for unstable objects and other hazards above and around you.
- Expect after shocks.

## **6. DO'S AND DON'TS**

### **6.1 DO's**

- Keep heavy objects at lower level, under bed, lower shelves
- Check for fire and, if any, have it controlled.
- Check your water and electrical lines for defects.
- If any damage is suspected, turn the system off from the main valve.

### **6.2 DON'Ts**

- Do not keep heavy objects on shelf and cupboard
- Do not enter partially damaged buildings. Strong aftershocks can cause further damage to the buildings and weak structures may collapse.
- Use telephone only for emergency purposes.
- Do not use your two-wheeler/car to drive around the areas of damage. Rescue and relief operations need the road for mobility.
- If gas is leaking, do not use matches, flashlights, appliances or electric switches.
- DO NOT PANIC !

## 7. REFERENCES:

1. IS 13828: 1993 (reaffirmed edition 2003) – Improving Earthquake resistance of low strength masonry buildings – Guidelines;
2. IS 1597 (part 1): 1992 (reaffirmed 2002) – Construction of Stone masonry code of practice;
3. IS 4326-1993 – Earthquake resistant design and construction of buildings – Code of practice;
4. Guideline for earthquake resistance reconstruction and new construction of masonry buildings in Jammu and Kashmir state: Prof. Anand S. Arya, National Seismic Advisor, Gol – UNDP DRM, Programme, Ministry of Home Affairs, Govt. of India (October 2005);
5. IITK-BMTPC Earthquake Tips: IIT Kanpur and Building Materials and Technology Promotion Council, New Delhi, India;
6. Handbook on good building design and construction – Aceh and Nias Islands, International Strategy for Disaster Reduction, UNDP
7. Earthquake Resistant Construction of Buildings - Curriculum for Mason Training, NSET – Nepal and ADPC, Feb 2005
8. Guidelines for Earthquake Resistant non- engineered construction – International Association for Earthquake Engineering & National Information Centre for Earthquake Engineering.